

SUN PARADISE®



THERMO 60

Faltwand • PSK *Folding Doors • PST*
Fenster • Festverglasung *Windows • Fixed Glazing*

Produkteinformation *Product Information*
Technische Zeichnungen *Technical Drawings*
Bestellformulare *Order Forms*

THERMO 60



System	System	A		
Faltwand	<i>Folding door</i>	A – B		F_TH_60
Deckenanschluss	<i>Top track</i>		01	
Bodenanschluss mit Anschlag; Sprosse	<i>Floor track; top hung</i>		02	
Bodenanschluss versenkbar	<i>Flush floor track; top hung</i>		03	
Bodenanschluss unten laufend; mit Anschlag	<i>Floor track; bottom running</i>		04	
Bodenanschluss unten laufend; versenkbar	<i>Flush floor track; bottom running</i>		05	
Wandanschluss Scharnierseite	<i>Jamb, hinge side</i>		06	
Wandanschluss Flügelseite	<i>Jamb, opening side</i>		07	
Wandanschluss Flügelseite Tribloc; innen öffnend	<i>Jamb, opening side with 3-point lock; inward open.</i>		08	
Wandanschluss Flügelseite Tribloc; aussen öffnend	<i>Jamb, opening side with 3-point lock; outward open.</i>		09	
Wandanschluss bei gerader Elementzahl	<i>Jamb opening side for even number of panels</i>		10	
Flügelverbindung	<i>Mullion detail</i>		11	
Mitte öffnend: 1L + 1R	<i>Centre opening: 1L + 1R</i>		12	
Mitte öffnend: 1L + 2R	<i>Centre opening: 1L + 2R</i>		13	
Mitte öffnend: 2L + 2R	<i>Centre opening: 2L + 2R</i>		14	
Eckverbindung 90°	<i>Corner post 90°</i>		15	
Eckverbindung 135°	<i>Corner post 135°</i>		16	
Parallel-Schiebe-Kipptüren	<i>Parallel slide and tilt doors</i>	C	17	P_TH_60
Festverglasung	<i>Fixed glazing</i>	D		V_TH_60
Festverglasung	<i>Fixed glazing</i>		18	
Festverglasung mit Brüstung	<i>Fixed glazing with sill profile</i>		19	
Fenster	<i>Window</i>	D		V_TH_60
Dreh- / Kipp-Fenster	<i>Tilt and turn window</i>		20	
Doppelflügel-Fenster	<i>Double window</i>		21	
Wandanschluss	<i>Wall connection detail</i>		22	
Fensterbankanschluss	<i>Window with sill connection</i>		23	
Zubehör	<i>Accessories</i>			
Ausgleichsprofil	<i>Compensation profile</i>		24	
Glasleisten und Glasdicken	<i>Glazing beads and glass thickness</i>		25	
Aufdoppelungen	<i>Extension profiles</i>		26	



SUNPARADISE Est.
 Benderer Strasse 29 • FL-9494 SCHAAN
 www.sunparadise.com • info@sunparadise.com
 Telefon +423 235 54 54 • Fax +423 235 54 55

SUNPARADISE Alutechnik Vertriebs GmbH
 Rickenbacher Strasse 1 • D-88131 LINDAU
 info-de@sunparadise.com
 Telefon +49 8382 977710 • Fax +49 8382 977712

S.E.&O.

Änderungen jederzeit vorbehalten.
 Subject to change without notice.

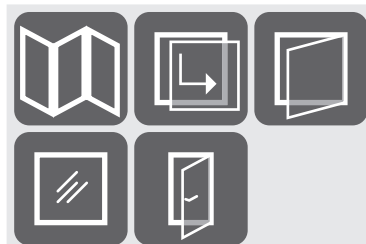
Komplettsystem

Das System THERMO 60 umfasst Faltwände und PSK-Anlagen, Einfach- und Doppelfenster, Festverglasungen und Türen. Alle sind einfach kombinierbar dank aufeinander ausgerichteter Profilmuten. Mit den dazu passenden Ausgleichsprofilen, Eckpfosten, Rahmenverbreiterungen etc. lässt sich die Verglasung an die verschiedensten Bauformen anpassen.

Complete system

THERMO 60 comprises folding doors and parallel-slide-and-tilt windows, single and double windows, fixed glazing and doors. All can easily be combined as they have matching profile grooves. Using integrated compensation profiles, corner posts, extension profiles etc., all types of diverse building requirements can be met.

Faltwand

aus thermisch getrennten Profilen.

Folding door

constructed from thermally broken aluminium sections.

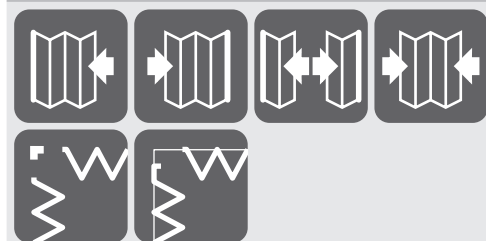
Konfiguration

Öffnung: nach links, rechts, mittig oder beidseitig; nach innen oder aussen faltend.

Ecken

Faltwände können übers Eck zusammenlaufen, mit festem oder mitlaufendem Pfosten. Standardecken mit 90° oder 135°.

Gestaltung

In die Faltwandelemente lassen sich auch Sprossen, Fensterflügel oder Lüfter integrieren.

Configuration

Opening: to the left, to the right, in the middle or both ways; stacking inside or outside.

Corners

Folding doors can meet at corners, with fixed or sliding posts. Standard corners of 90° or 135°.

Design freedom

Transoms, windows, vents etc. can be incorporated.

Besonderheiten

Der Anschlag dieser Bodenschiene kann abgeklappt werden, um ein Stolpern zu verhindern.

Characteristic features

The flush track option has a folding weather bar to eliminate trip hazard when the doors are open.

Aufhängung





Die Faltwand kann wahlweise oben hängend oder unten aufstehend geliefert werden. Wir empfehlen, die Faltwand immer möglichst oben hängend auszuführen, da die Gefahr einer Verschmutzung im Bereich der Laufrollen wesentlich kleiner ist.







Höhenverstellbare Laufwagen oben oder unten ermöglichen ein einfaches Nachjustieren der eingebauten Faltwand. Kardanisch gelagerte Laufrollen mit Kugellager aus Edelstahl.

Suspension

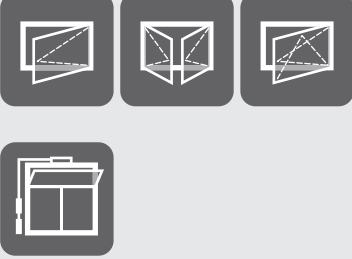
The folding door is available in the following options: Top hung or floor supported. We recommend the doors be top hung wherever possible, as the effect of dirt accumulating in the floor track is considerably reduced with this option. Height adjustable bogie trolleys above or below allow for simple readjustment of doors after installation. Cardanic rollers with stainless steel ball bearings.

	<p>Reinigung Ausziehbare Scharnierdorne erleichtern bei nach innen faltenden Flügeln den Zugang zur Aussenseite für die Scheibenreinigung.</p>	<p>Cleaning <i>On inward folding doors, removable hinge pins allow access to the outside panels for cleaning purposes.</i></p>
 	<p>Verschlussarten Standard: Öffnung von innen mit Flachgriffen 180°. Bei ungerader Elementzahl kann das erste Element wie eine Türe geöffnet werden. Beidseitig öffnend mit Zylinderausschnitt: Stangenverschluss 3 Punkt mit Handgriff gerade 180° auf der Seite, nach der die faltwand öffnet und Handgriff gekröpft gegenüber. Bei stärkerer Nutzung: Triblocschloss mit Zylinderausschnitt, Türfalle und Schliessblech.</p>	<p>Lock types <i>Standard: opening from the inside with shootbolts operated by 180° flat handles. With uneven number of elements, the first element can be used like a door.</i> <i>Opening from both ends with cylinder cut-out: 3-way bar lock with 180° straight handle on the folding side and cranked handle on the opposite side.</i> <i>For heavy-duty use: 'Tribloc' Three point lock with cylinder cut-out, catch and plate.</i></p>
	<p>Technische Details Alle Beschläge aus korrosionsbeständigen Werkstoffen.</p>	<p>Technical Details <i>All ironmongery parts are made of corrosion resistant materials.</i></p>
	<p>Verglasung Isolierglas: 16 – 32mm Füllungen: max 42mm</p>	<p>Glazing <i>Toughened double glazing: 16 – 32mm</i> <i>Various thermal glazing available</i></p>
	<p>Dimensionen Elementbreite: max. 1000mm Elementhöhe: max. 2700mm Schienenlänge ohne Stoss: max. 6800mm</p>	<p>Dimensions <i>Panel width: max. 1000mm</i> <i>Panel height: max. 2700mm</i> <i>Track length without joint: max. 6800mm</i></p>

	<p>PSK Die THERMO 60 Parallel-Schiebe-Kippfenster erlauben bei geringer Bautiefe grosse Flügel und Fensteröffnungen.</p>	<p>PST <i>Parallel-slide-and-tilt windows allow for large wings and openings with slimline system.</i></p>
	<p>Konfiguration PSK lassen sich konfigurieren mit 2, 3 oder 4 Elementen, nach links oder rechts schiebend. Das Festelement kann auch als Blindflügel zur Aussenreinigung ausgeführt werden.</p>	<p>Configuration <i>PST systems can feature 2, 3 or 4 elements, sliding towards left or right. The fixed element can be hinged for outside cleaning access.</i></p>
	<p>Verschluss Der 180° Drehgriff ist auf Wunsch auch abschliessbar erhältlich. Für Blindflügel gibt es einen abnehmbaren Handgriff. Beschlag mit Zwangseinzug ist optional, ab Flügelbreite 1650mm zwingend. Verschlussriegelhöhe mindestens 300mm, bei Zwangseinzug 500mm.</p>	<p>Lock <i>The standard 180° lever can also be ordered with a key lock. For cleaning access to the fixed element a detachable handle can be used. Automatic tilt closure systems are necessary from 1650mm width upward. Minimum locking bolt height is 300mm, with automatic closure 500mm.</i></p>
	<p>Dimensionen Flügelmasse: Breite: 700 – 2400mm Höhe: 850 – 2400mm Gewicht: bis 150kg</p>	<p>Dimension Sash size: Width: 700 – 2400mm Height: 850 – 2400mm Weight: max. 150kg</p>

	<p>Fenster Individuelles Sortiment von Einzel- und Doppel-flügel Fenstern.</p>	<p>Window <i>Versatile programme of single and double windows.</i></p>
	<p>Konfiguration Dreh-, Kipp- und Drehkipp-Fenster; Doppelflügel-fenster auf Wunsch mit einem Drehkipp-Flügel. Stulpflügel mit Kantenriegel. Oberlichter als Kippfenster mit Schnäpper, Kurbelstange, Schnurzug oder elektrischem Kettenmotor (24V oder 230V)</p>	<p>Configuration <i>Turning, bottom hung or tilt-and-turn; double window with optional tilt-and-turn sash. Mullion with frame latch. Fanlight bottom-hinged with catch, crank shaft, rope action or electric chain motor (24V or 230V).</i></p>
	<p>Gestaltung In die Fenster lassen sich auch Sprossen oder Lüfter integrieren. Fenster und Sprossen lassen sich auch durch Abschrägungen individuell gestalten.</p>	<p>Design <i>Transoms or vents can be incorporated. Oblique corners and transoms allow wide design options.</i></p>
	<p>Dimensionen Dreh- und Drehkippfenster bis: Breite: 1200mm Höhe: 2400mm Gewicht: 100kg/(130kg) Doppelfenster bis: Breite: 2400mm Höhe: 2400mm Gewicht: 200kg Kippfenster: bei Kurbelgetriebe sind mittels Zusatzscheren auch grössere Breiten möglich.</p>	<p>Dimensions <i>Turning and/or tilting windows up to:</i> <i>Width: 1200mm</i> <i>Height: 2400mm</i> <i>Weight: 100kg/(130kg)</i> <i>Double windows up to:</i> <i>Width: 2400mm</i> <i>Height: 2400mm</i> <i>Weight: 200kg</i> <i>Bottom hung windows can be made wider with additional shears.</i></p>
	<p>Festverglasung Flexible Ergänzung zu Fenstern und Türen; Füllung mit Isolierglas oder Dämmpaneelen.</p>	<p>Fixed glazing <i>Flexible complement to windows and doors; with thermal glazing or insulated panels.</i></p>
	<p>Gestaltung Abschrägungen etc. nach Kundenwunsch</p>	<p>Design <i>Oblique corners etc. to project specification.</i></p>
	<p>Dimensionen Sehr flexibel; maximale Transportgrösse als Rahmen: 6000mm x 2300mm</p>	<p>Dimensions <i>Very flexible; max. transport size of completed frame is: 6000mm x 2300mm</i></p>

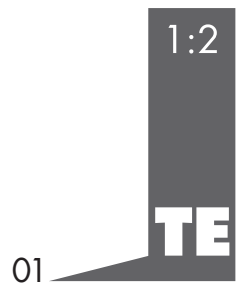
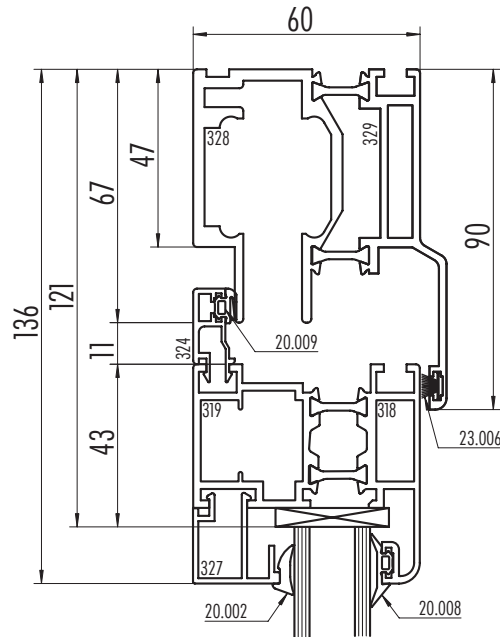

Bodenanschluss mit Anschlag; Sprosse
Floor track; top hung

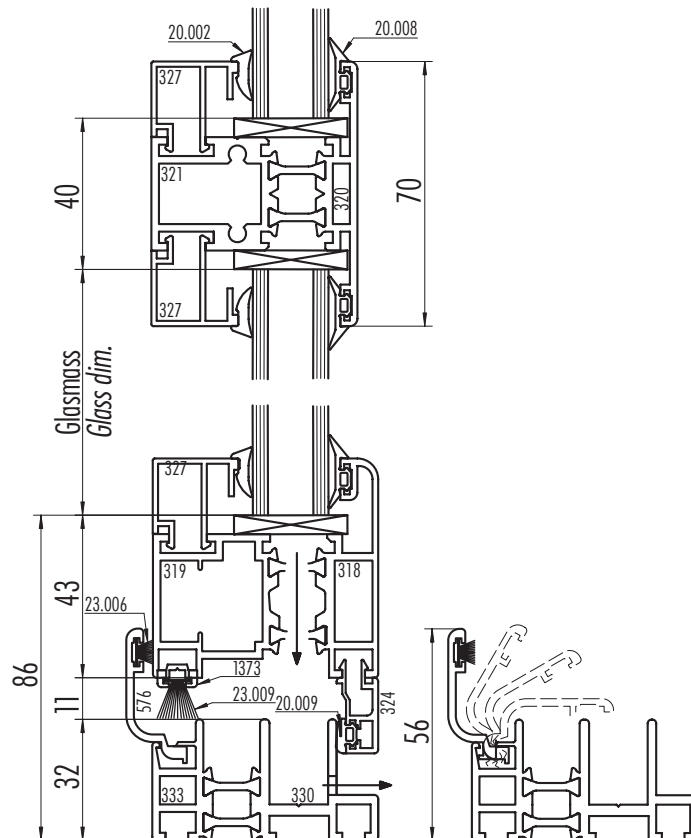

Bodenanschluss versenkbar
Flush floor track; top hung

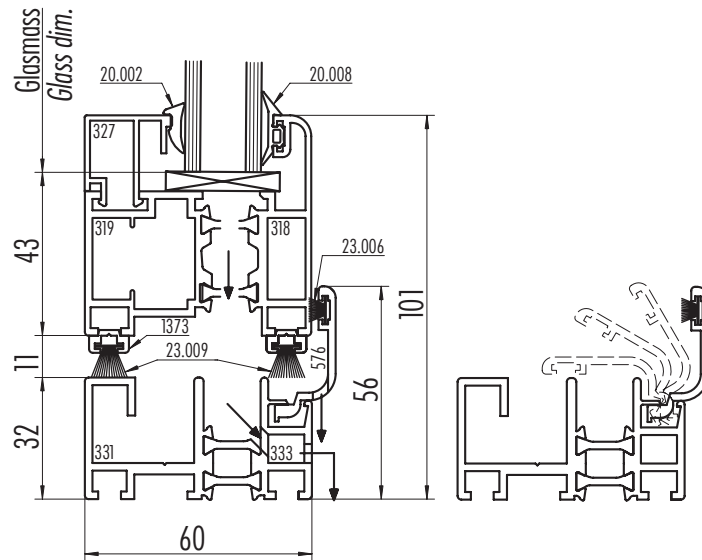

1:2

TE

03

Bodenanschluss unten laufend; mit Anschlag
Floor track; bottom running

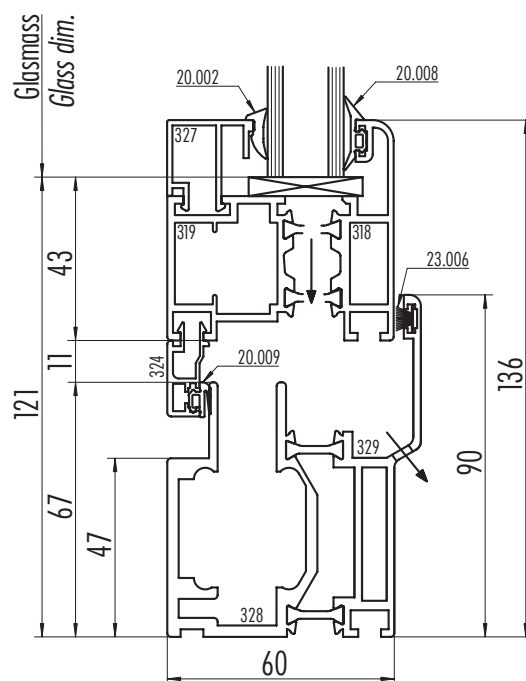

1:2

TE

04

Bodenanschluss unten laufend; versenkbar
Flush floor track; bottom running

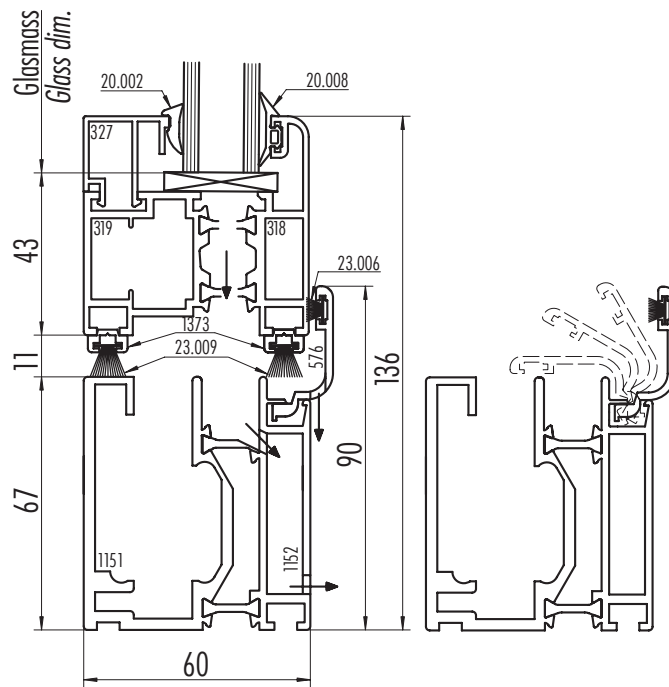

1:2
TE
 05

Wandanschluss Scharnierseite
Jamb, hinge side

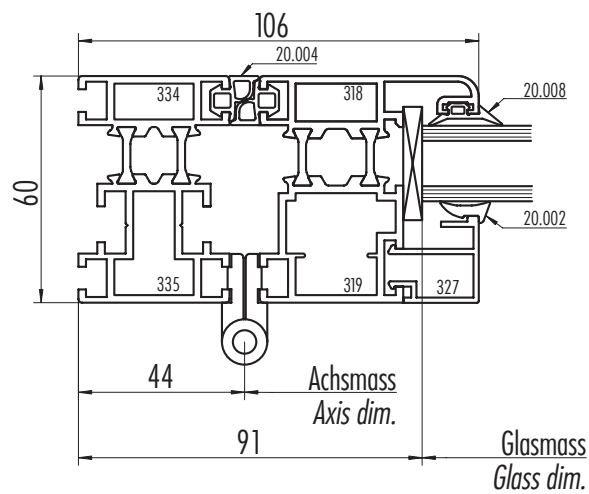

1:2
TE
 06

Wandanschluss Flügelseite
Jamb, opening side

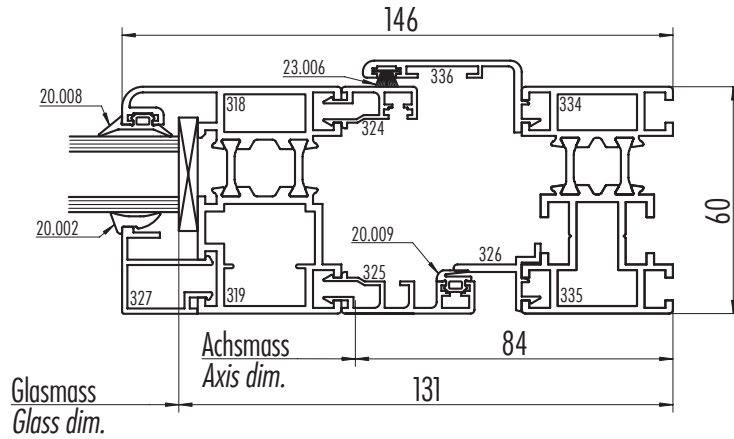

1:2

TE

07

Wandanschluss Flügelseite Tribloc; innen öffnend
Jamb, opening side with 3-point lock; inward opening

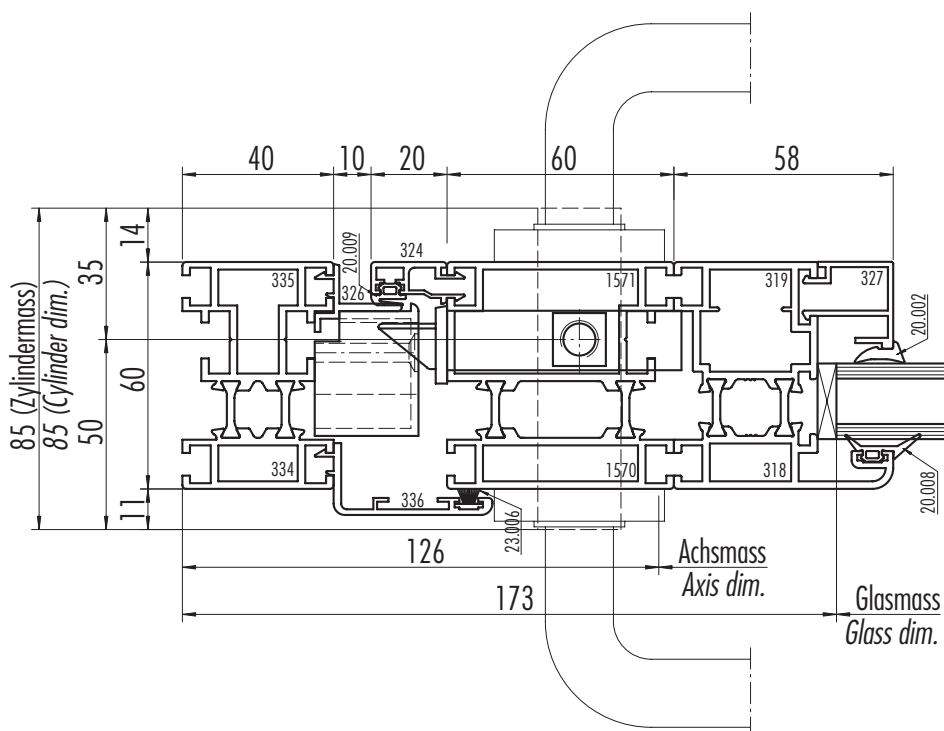

1:2

TE

08

Wandanschluss Flügelseite Tribloc; aussen öffnend
Jamb, opening side with 3-point lock; outward opening

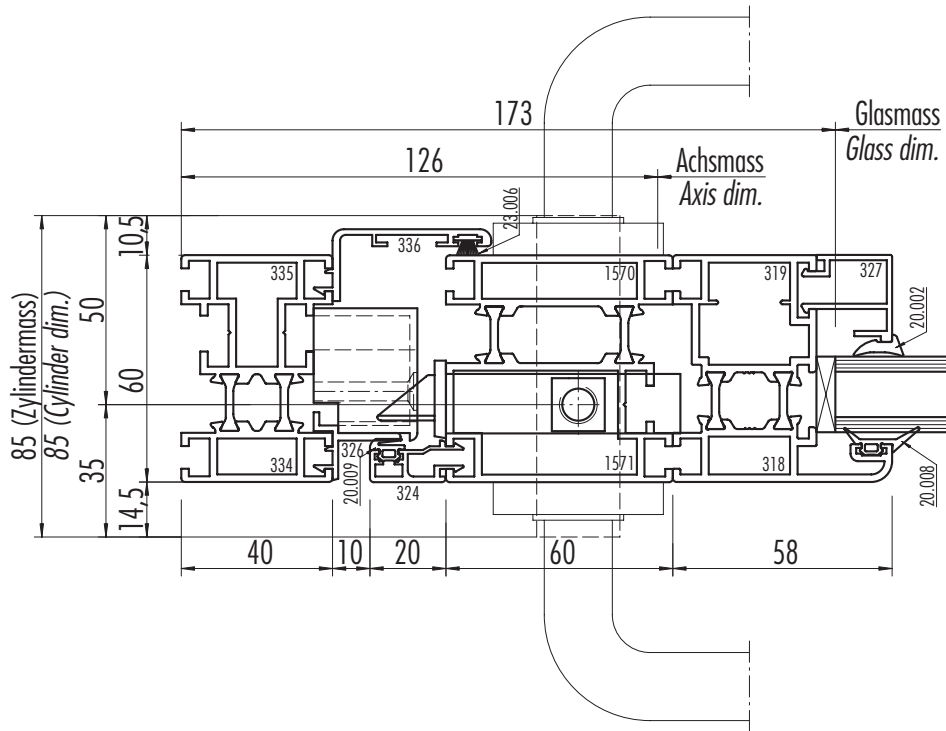

1:2

TE

09

Wandanschluss bei gerader Elementzahl
Jamb opening side for even number of panels

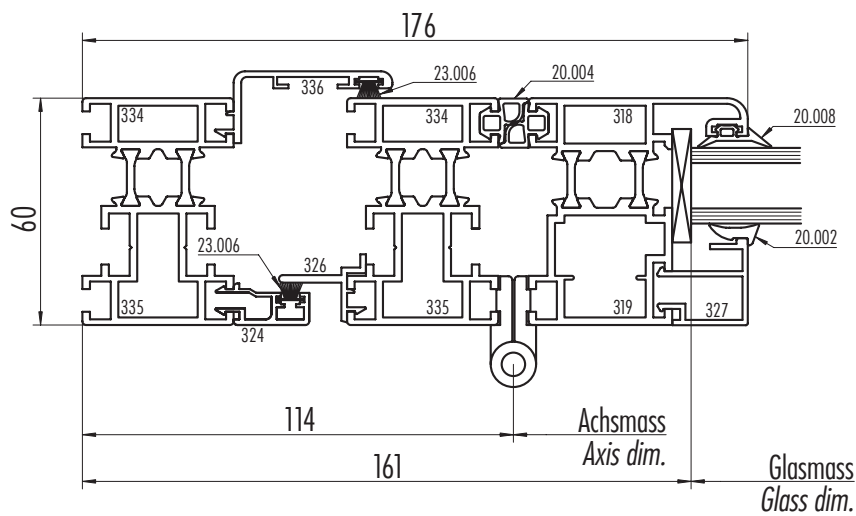

1:2

TE

10

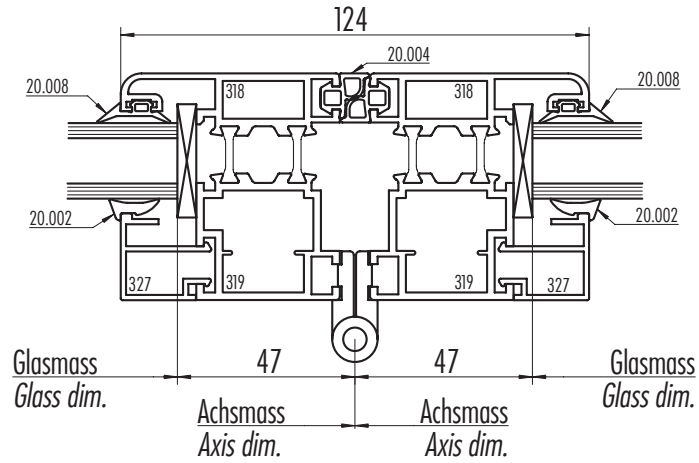

1:2

TE

11

Mitte öffnend: 1L + 1R
Centre opening: 1L + 1R

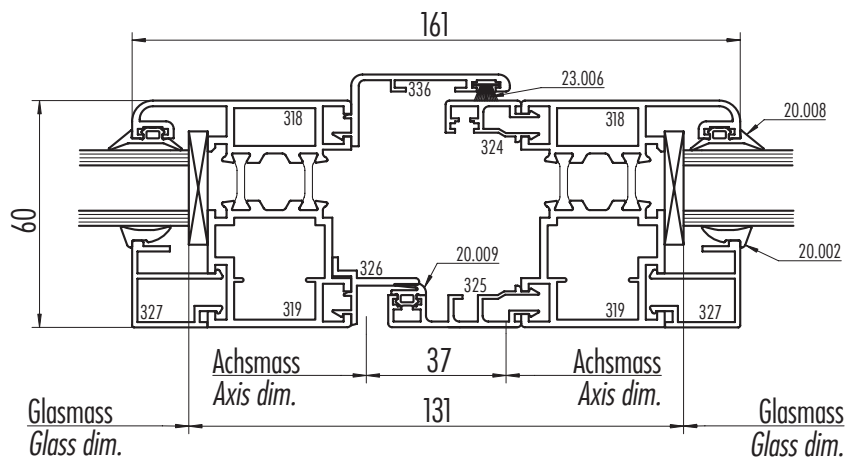

1:2

TE

12

Mitte öffnend: 1L + 2R
 Centre opening: 1L + 2R

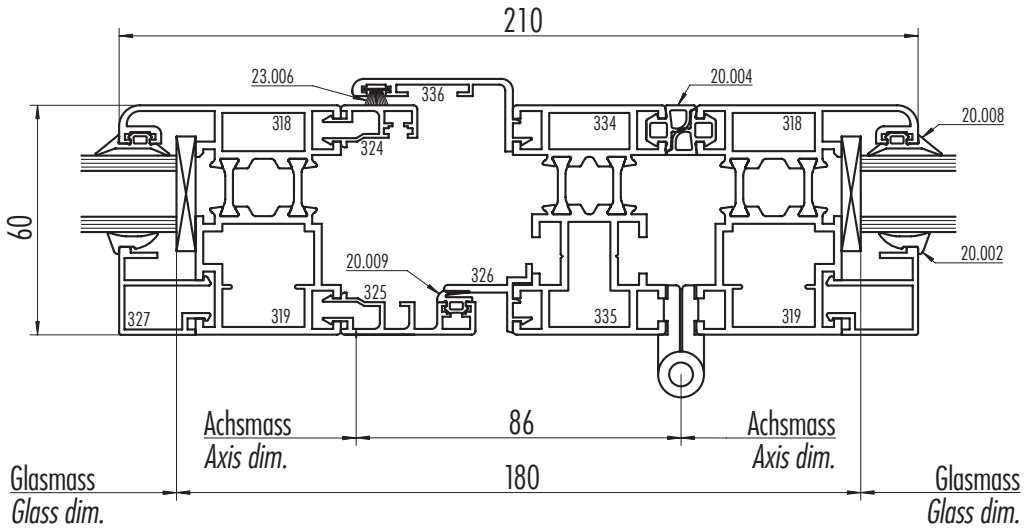

1:2
TE

13

Mitte öffnend: 2L + 2R
 Centre opening: 2L + 2R

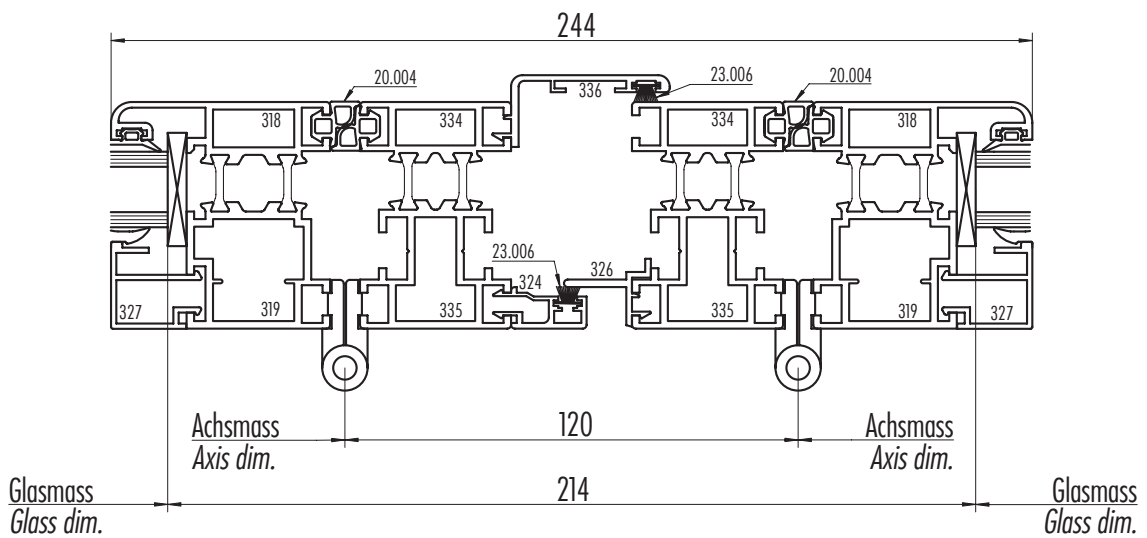

1:2
TE

14

Eckverbindung 90°
Corner post 90°

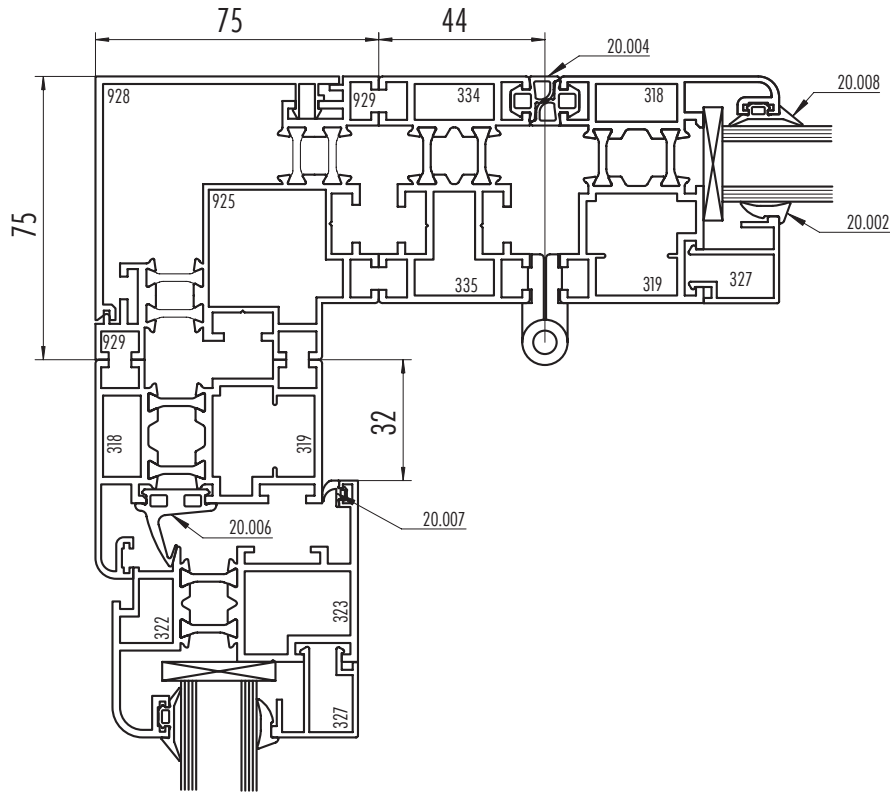

1:2

TE

15

Eckverbindung 135°
Corner post 135°

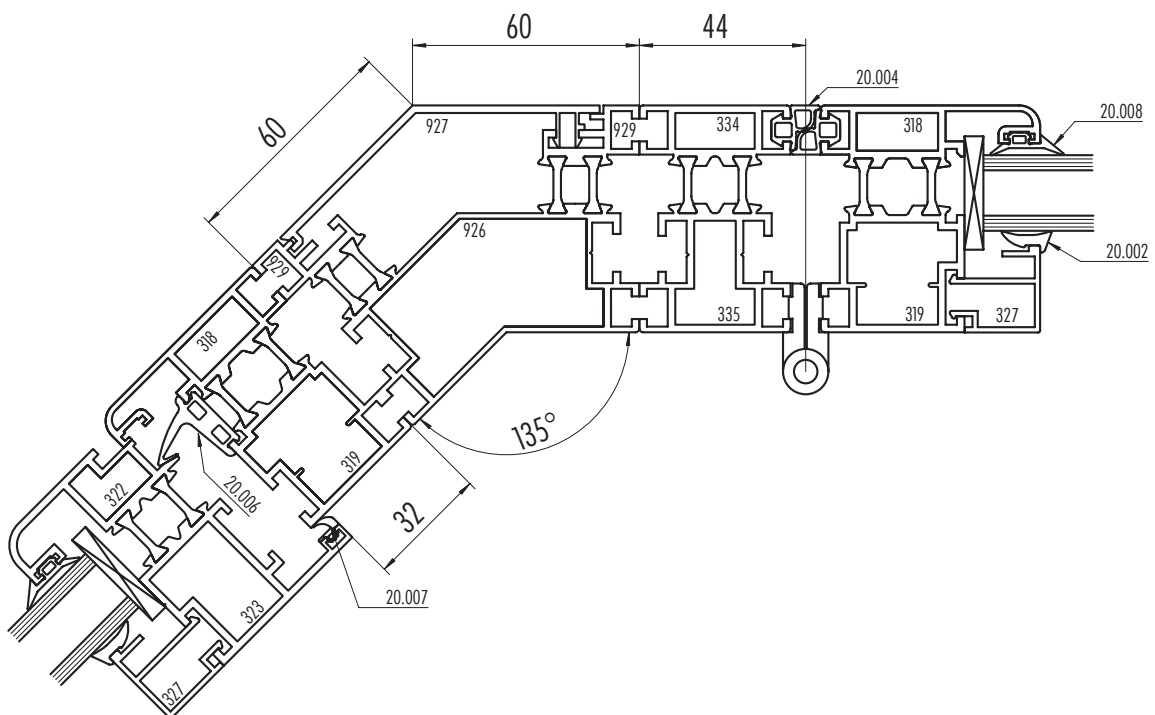

1:2

TE

16

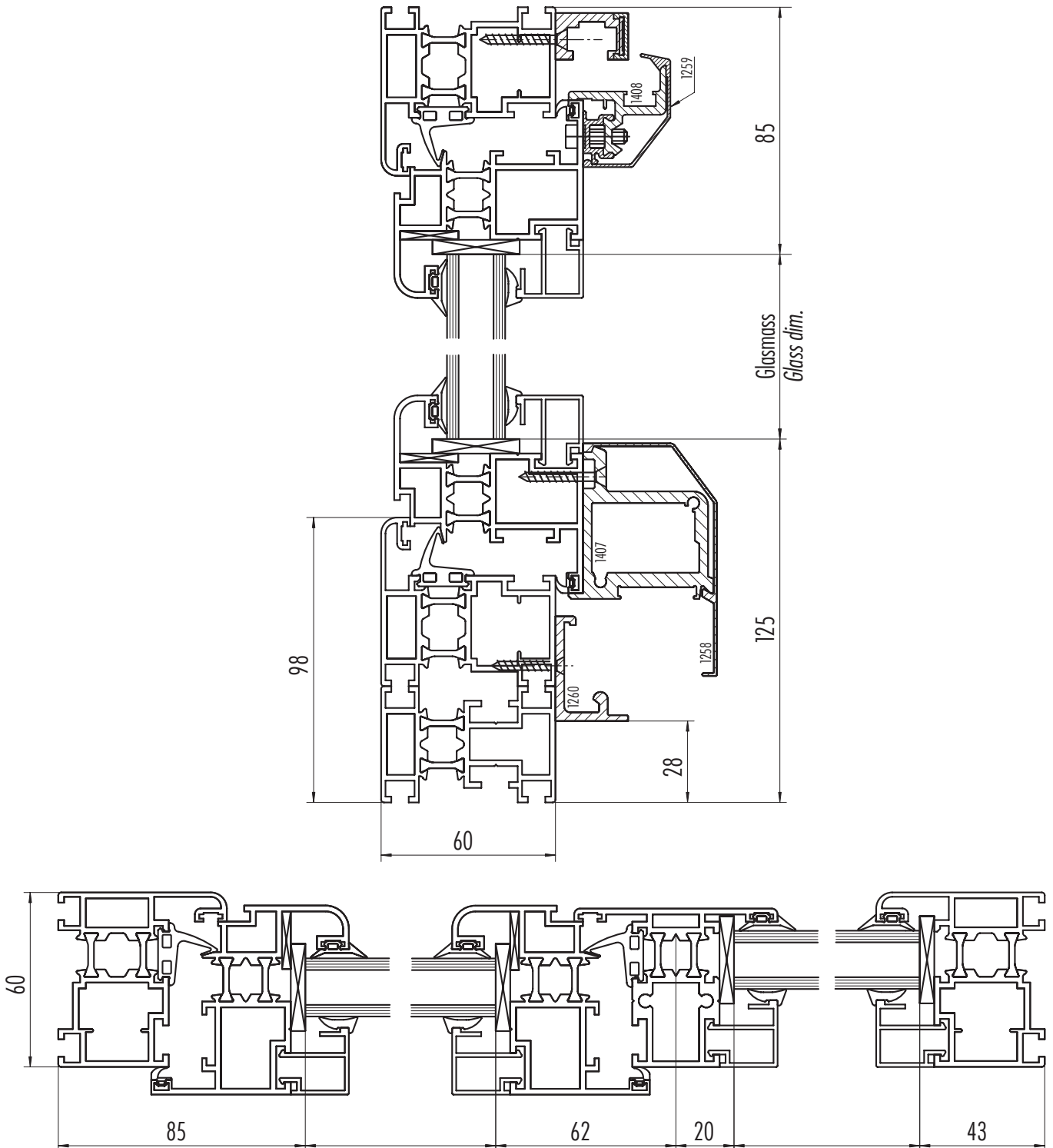

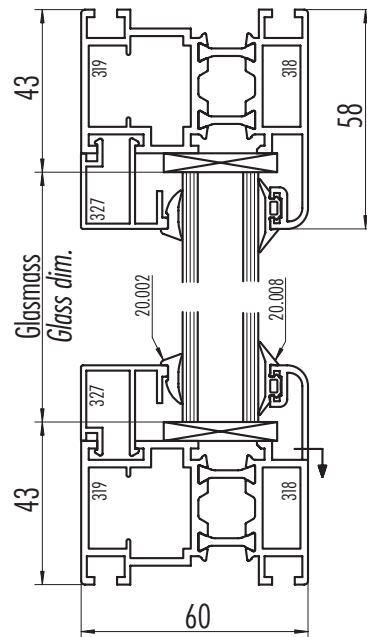

1:2

TE

18

Festverglasung mit Brüstung
Fixed glazing with sill profile

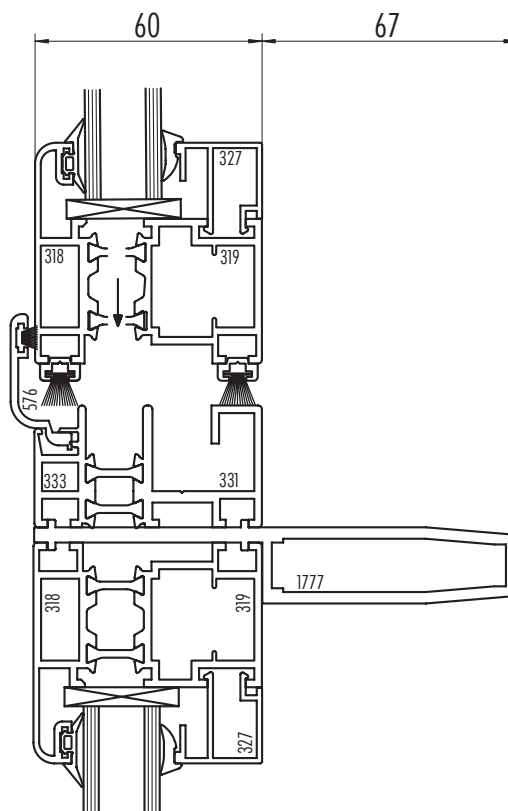

1:2

TE

19

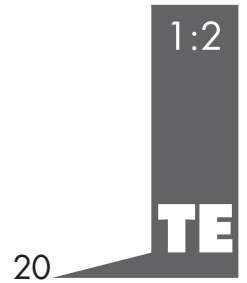
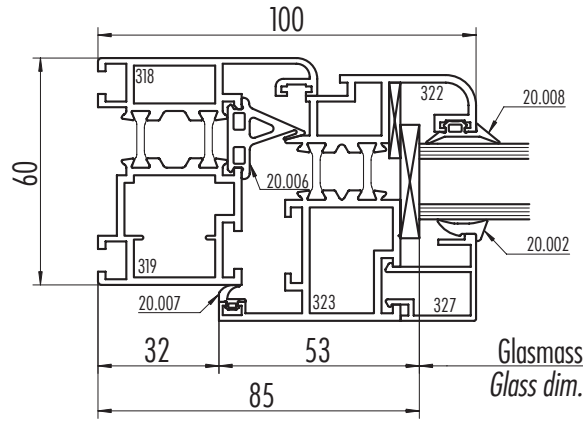

Doppelflügel Fenster
Double window

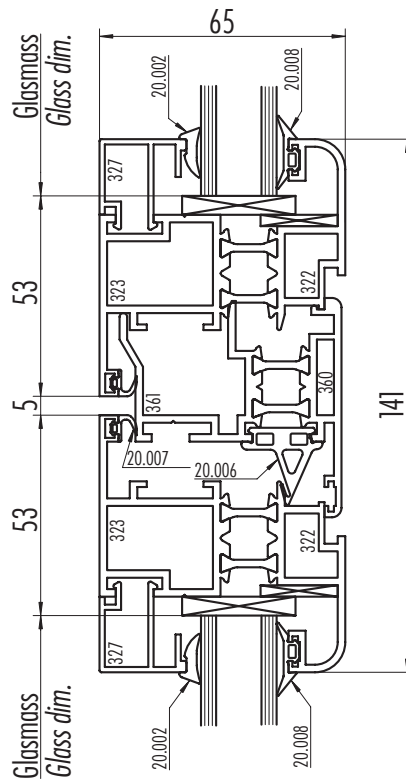

Wandanschluss
Wall connection detail

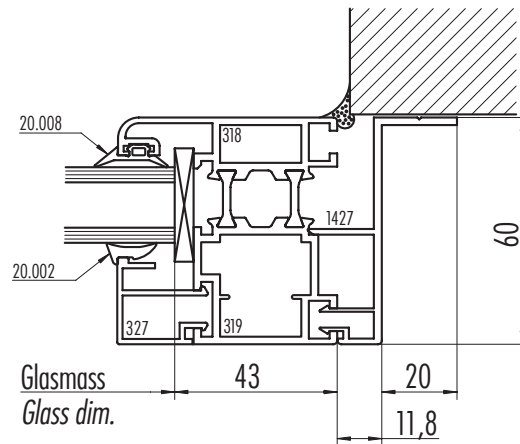

1:2

TE

22

Fensterbankanschluss
Window with sill connection

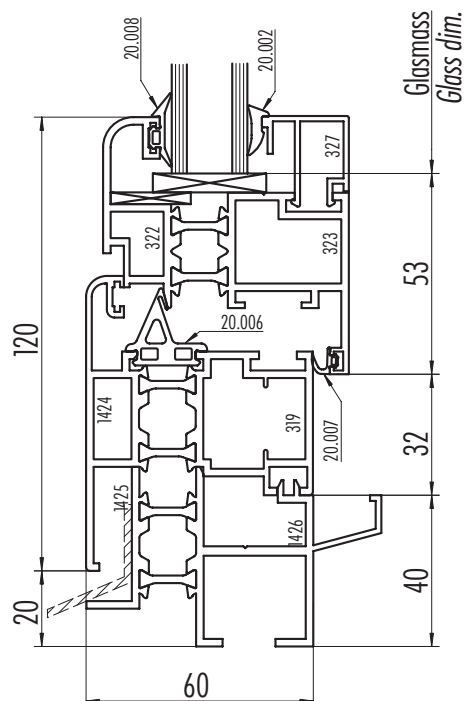

1:2

TE

23

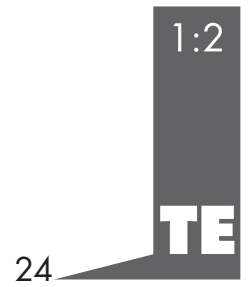
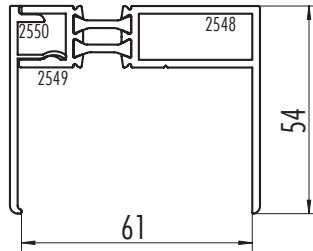

Glisleisten und Glasdicken
Glazing beads and glass thickness

KEILGUMMI / GASKET			
Nr.	Glasdicken	Nr.	Glasdicken
No.	Glass thickness	No.	Glass thickness
20.003	18 – 19mm	20.002	20 – 21mm

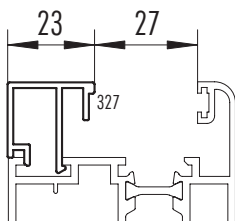

KEILGUMMI / GASKET			
Nr.	Glasdicken	Nr.	Glasdicken
No.	Glass thickness	No.	Glass thickness
20.003	22mm	20.047	23mm
20.002	24 – 25mm		

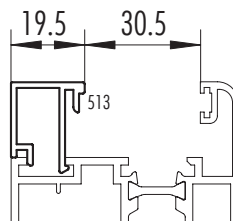

KEILGUMMI / GASKET			
Nr.	Glasdicken	Nr.	Glasdicken
No.	Glass thickness	No.	Glass thickness
20.003	26 – 27mm	20.047	28mm
20.002	29mm		

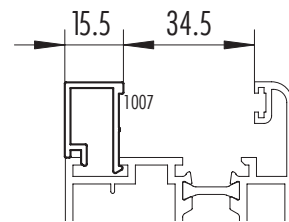

KEILGUMMI / GASKET			
Nr.	Glasdicken	Nr.	Glasdicken
No.	Glass thickness	No.	Glass thickness
20.003	30mm	20.047	31mm
20.002	32mm		

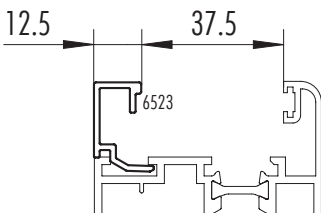

KEILGUMMI / GASKET			
Nr.	Glasdicken	Nr.	Glasdicken
No.	Glass thickness	No.	Glass thickness
20.003	33mm	20.047	34mm
20.002	35mm		

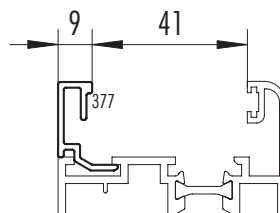

KEILGUMMI / GASKET			
Nr.	Glasdicken	Nr.	Glasdicken
No.	Glass thickness	No.	Glass thickness
20.003	36mm	20.047	37mm
20.002	38mm		

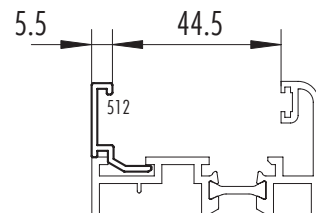

KEILGUMMI / GASKET			
Nr.	Glasdicken	Nr.	Glasdicken
No.	Glass thickness	No.	Glass thickness
20.003	39mm	20.002	40 – 41mm
20.001	42mm		

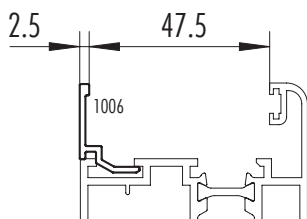

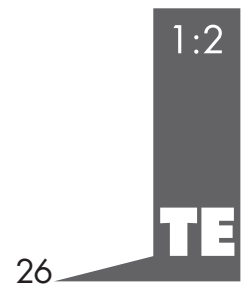
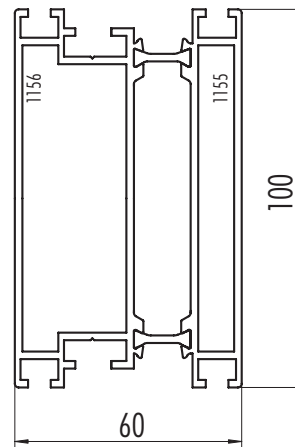
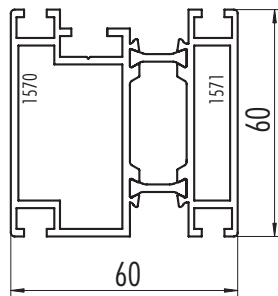
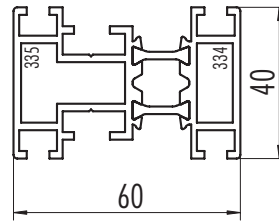
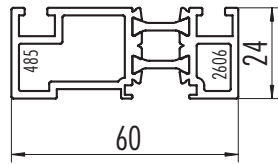

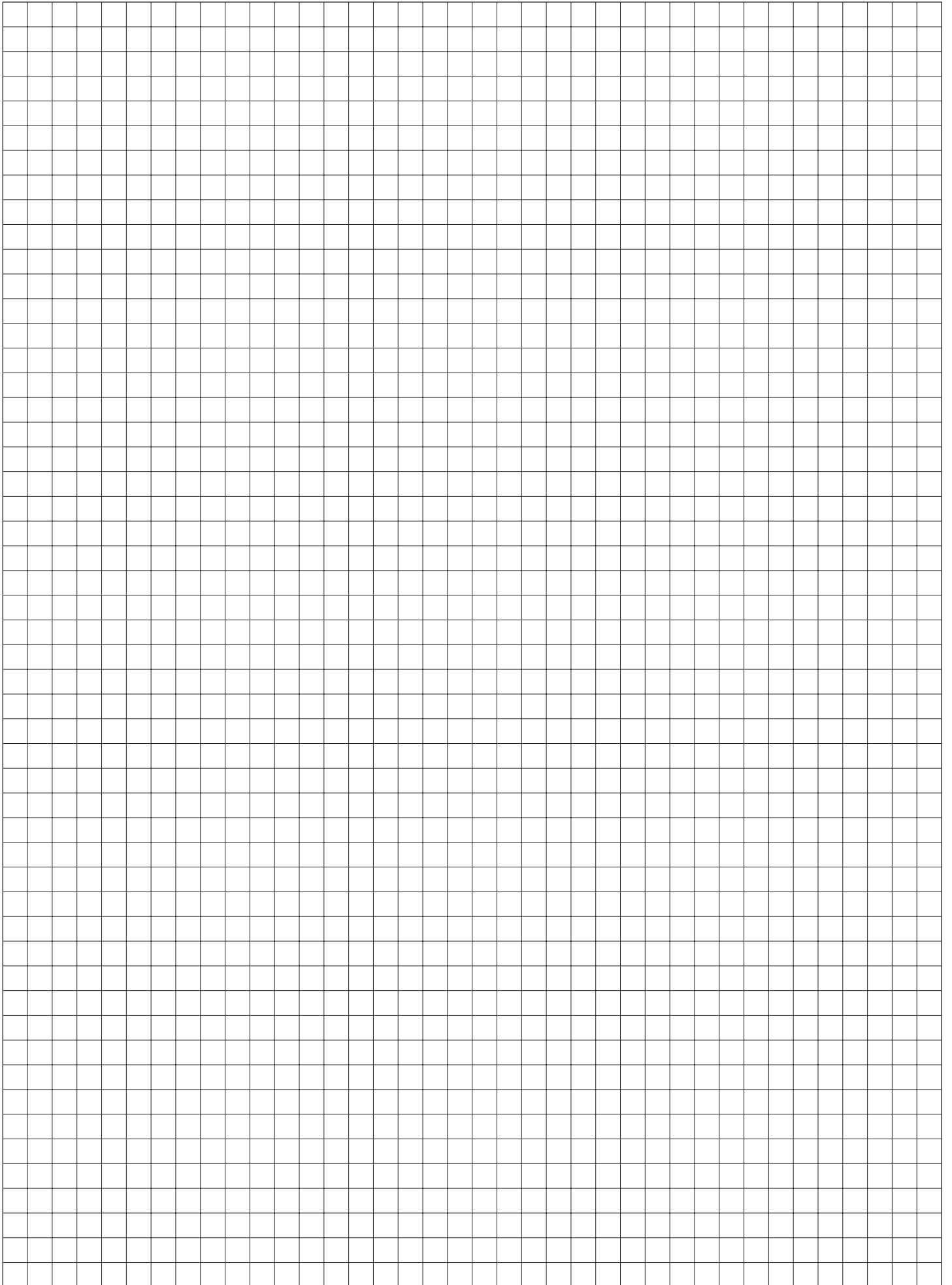

Customer _____

Reference _____

Delivery WK No. [min 4 weeks] _____

E-Mail: _____

Place/Date _____

Number of enclosures (Plan/Sketch): _____

Signature _____

Details

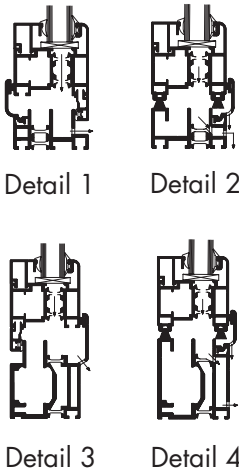

Detail 1 Detail 2
Detail 3 Detail 4

Plan/Sketch viewed from inside

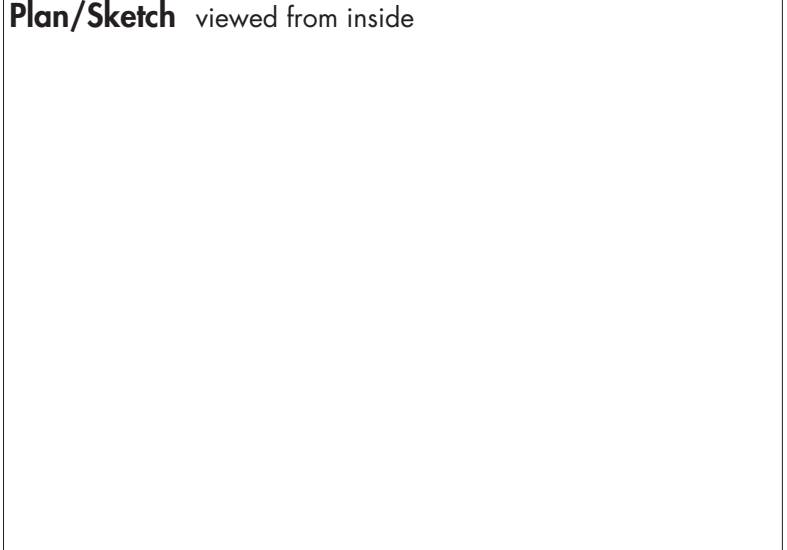

Opening dimensions	Width(mm) _____	No. of panels _____
	Height(mm) _____	Transom [top] (mm) _____
Suspension	Top running with threshold detail <input type="radio"/> Detail 1 <input type="radio"/> Detail 2 <input type="radio"/> Detail 3 <input type="radio"/> Detail 4	
	Bottom running with threshold detail <input type="radio"/> Detail 3 <input type="radio"/> Detail 4	
Folding door opening (inside view)	<input type="radio"/> to the Left <input type="radio"/> to the Right <input type="radio"/> from both sides <input type="radio"/> centre	
Panel stack position	<input type="radio"/> Inside <input type="radio"/> Outside	
Door element	<input type="radio"/> Standard: Flat handle <input type="radio"/> Cylinder lock cut-out + handles both sides	
	<input type="radio"/> Profile cylinder type 17mm <input type="radio"/> 3-Point lock cut-out + handles both sides	
Locking bolt height from u/s floor guide	<input type="radio"/> Standard: 1100mm <input type="radio"/> Other: min.300(mm) _____	
Removable hinge pins for cleaning	<input type="radio"/> Yes <input type="radio"/> No	
Glazing	<input type="radio"/> With <input type="radio"/> Without <input type="radio"/> double glazed 24mm <input type="radio"/> prepared for (mm) _____	
Alu-frame	Inside <input type="radio"/> Natur. anod. <input type="radio"/> RAL 9010 <input type="radio"/> Other Colour _____	
	Outside <input type="radio"/> Natur. anod. <input type="radio"/> RAL 9010 <input type="radio"/> Other Colour _____	
Ironmongery	Inside <input type="radio"/> Black <input type="radio"/> White <input type="radio"/> Aluminium col.	
	Outside <input type="radio"/> Black <input type="radio"/> White <input type="radio"/> Aluminium col.	
EPDM/TPV	Inside <input type="radio"/> Black <input type="radio"/> White <input type="radio"/> Grey	
Gaskets	Outside <input type="radio"/> Black <input type="radio"/> White <input type="radio"/> Grey <input type="radio"/> silicone-free	
Compensation profile* 54mm	<input type="radio"/> Top <input type="radio"/> Bottom <input type="radio"/> Left** <input type="radio"/> Right**	

Remark _____

***Watch the height! **Inside view**

Kunde _____		Komm. _____
_____		Termin KW [min. 4 Wochen] _____
E-Mail: _____	Ort/Datum _____	
Anzahl Beilagen (Plan/Skizze): _____	Unterschrift _____	

Details

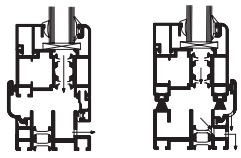

Detail 1 Detail 2

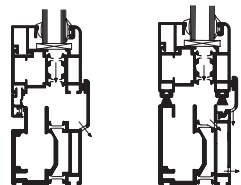

Detail 3 Detail 4

Plan/Skizze von innen gesehen

Blank area for drawing the door plan from the inside.

Faltwand	Breite(mm) _____	Teilung _____			
	Höhe(mm) _____	Sprossenhöhe – o.k. Sprosse(mm) _____			
Faltwand	Oben laufend mit Bodendetail	<input type="radio"/> Detail 1	<input type="radio"/> Detail 2	<input type="radio"/> Detail 3	<input type="radio"/> Detail 4
Details	Unten laufend mit Bodendetail			<input type="radio"/> Detail 3	<input type="radio"/> Detail 4
Faltwand-Öffnung (von innen gesehen)	<input type="radio"/> nach Links	<input type="radio"/> nach Rechts	<input type="radio"/> beidseitig	<input type="radio"/> mittig	
Faltwandpaket Lage	<input type="radio"/> Innen	<input type="radio"/> Aussen			
Türelement	<input type="radio"/> Standard: Flachgriff				
	<input type="radio"/> Schlossausschnitt mit Drückergarnitur	<input type="radio"/> Rundzylinderausschnitt 22mm			
	<input type="radio"/> Tribloc-Schloss mit Drückergarnitur	<input type="radio"/> Profolzylinderausschnitt 17mm			
Verschlussriegelhöhe ab u.k. Bodenführung	<input type="radio"/> Standard: 1100mm	<input type="radio"/> Andere: min. 300(mm) _____			
Reinigungsdorne	<input type="radio"/> Ja	<input type="radio"/> Nein			
Verglasung	<input type="radio"/> Mit	<input type="radio"/> Ohne	<input type="radio"/> Isolierglas – Dicke 24mm	<input type="radio"/> hergerichtet für(mm) _____	
Aluprofile	Innen	<input type="radio"/> natur elox.	<input type="radio"/> RAL 9010	<input type="radio"/> andere Farbe _____	
	Aussen	<input type="radio"/> natur elox.	<input type="radio"/> RAL 9010	<input type="radio"/> andere Farbe _____	
Beschläge	Innen	<input type="radio"/> Schwarz	<input type="radio"/> Weiss	<input type="radio"/> Alu-farbig	
	Aussen	<input type="radio"/> Schwarz	<input type="radio"/> Weiss	<input type="radio"/> Alu-farbig	
EPDM/TPV	Innen	<input type="radio"/> Schwarz	<input type="radio"/> Weiss	<input type="radio"/> Grau	
Dichtung	Aussen	<input type="radio"/> Schwarz	<input type="radio"/> Weiss	<input type="radio"/> Grau	<input type="radio"/> silikonfrei
Ausgleichsprofil* 54mm	<input type="radio"/> Oben	<input type="radio"/> Unten	<input type="radio"/> Links**	<input type="radio"/> Rechts**	

Bemerkung _____

*Höhe beachten **Von innen

FORM_F_TH_60



PARALLEL-SLIDE-AND-TILT DOOR **THERMO 60**

Customer	Reference
	Delivery WK No. [min 4 weeks]
E-Mail:	Place/Date
Number of enclosures (Plan/Sketch):	Signature

Details

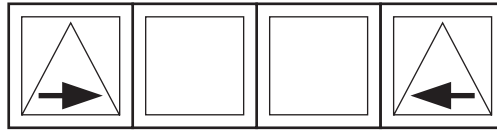
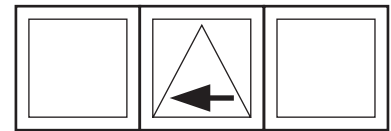
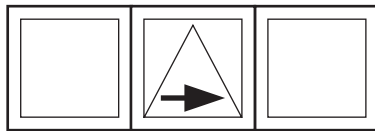
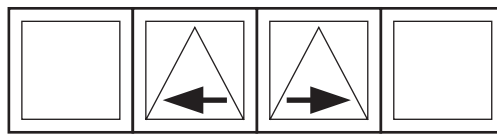
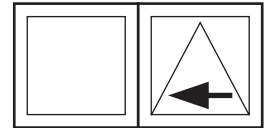
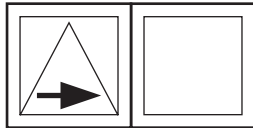

Casement sizes are valid for all types

Width: 700 – 2400mm / Height: 850 – 2400mm / Weight: 150kg

Parallel-slide-and-tilt door	Width(mm) _____	<input type="radio"/> Forced tilt closure (>1650mm/150kg required)	
	Height(mm) _____	Transom height [top] (mm) _____	
Locking bolt height from u/s floor guide	<input type="radio"/> 1100mm	<input type="radio"/> Other:min 300/500(mm) _____	
Alu-frame	Inside	<input type="radio"/> Natur. anod. <input type="radio"/> RAL 9010 <input type="radio"/> Other Colour _____	
	Outside	<input type="radio"/> Natur. anod. <input type="radio"/> RAL 9010 <input type="radio"/> Other Colour _____	
Glazing	<input type="radio"/> With <input type="radio"/> Without <input type="radio"/> double glazed 24mm <input type="radio"/> prepared for (mm) _____		
Fixed casement opening for external cleaning	<input type="radio"/> Left <input type="radio"/> Right		
Handle	<input type="radio"/> with integrated lock		
Ironmongery	Inside	<input type="radio"/> Black <input type="radio"/> White <input type="radio"/> Aluminium col.	
	Outside	<input type="radio"/> Black <input type="radio"/> White <input type="radio"/> Aluminium col.	
EPDM/TPV	Inside	<input type="radio"/> Black <input type="radio"/> White <input type="radio"/> Grey	
Gaskets	Outside	<input type="radio"/> Black <input type="radio"/> White <input type="radio"/> Grey <input type="radio"/> silicone-free	
Compensation profile* 54mm	<input type="radio"/> Top <input type="radio"/> Bottom <input type="radio"/> Left** <input type="radio"/> Right**		

Remark _____

***Watch the height! **Inside view**

FORM_P_TH_60



Kunde _____

Komm. _____

Termin KW [min. 4 Wochen] _____

E-Mail: _____

Ort/Datum _____

Anzahl Beilagen (Plan/Skizze): _____

Unterschrift _____

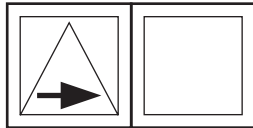
Details

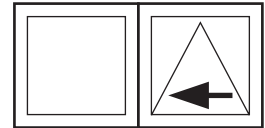

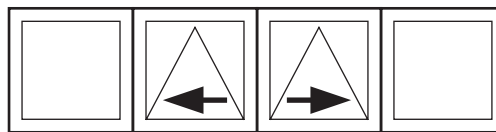

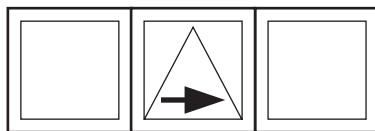

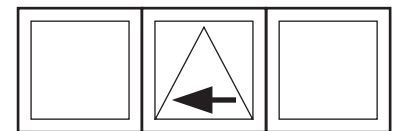

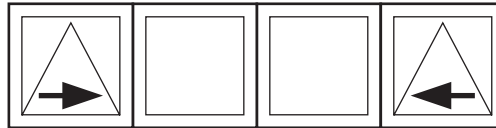

Flügelmasse gelten für alle Typen

Breite: 700 – 2400mm / Höhe: 850 – 2400mm / Gewicht: 150kg

Parallel-Schiebe-Kipptüre

 Breite(mm) _____ Zwangseinzug (ab 1650mm/150kg zwingend)

Höhe(mm) _____ Sprossenhöhe – o.k. Sprosse(mm) _____

Verschlussriegelhöhe ab u.k. Bodenführung 1100mm Andere: min.300/500(mm) _____

Aluprofile Innen natur elox. RAL 9010 andere Farbe _____

 Aussen natur elox. RAL 9010 andere Farbe _____

Verglasung Mit Ohne Isolierglas – Dicke 24mm hergerichtet für(mm) _____

Blindflügel zur Aussenreinigung Links Rechts

Handgriff abschliessbar

Beschläge Innen Schwarz Weiss Alu-farbig

 Aussen Schwarz Weiss Alu-farbig

EPDM/TPV Innen Schwarz Weiss Grau

 Dichtung Aussen Schwarz Weiss Grau silikonfrei

Ausgleichsprofil* 54mm Oben Unten Links** Rechts**

Bemerkung _____

***Höhe beachten **Von innen**

FORM_P_TH_60



WINDOWS, FIXED GLAZING **THERMO 60**

Customer _____

Reference _____

Delivery WK No. [min 4 weeks] _____

E-Mail: _____

Place/Date _____

Number of enclosures (Plan/Sketch): _____

Signature _____

Glazing viewed from inside

 Fixed glazing

 Bottom hung window

 Left side hung window

 Double-wing window
 First-opening: Left Right

 Right side hung window

 Double-wing window with tilt and turn casement Left

 Left side tilt and turn window

 Double-wing window with tilt and turn casement Right

 Right side tilt and turn window

 with frame latch

Plan/Sketch viewed from inside

Dimensions

Width(mm) _____

Height(mm) _____ Transom height [top] (mm) _____

Skylight opener

 Snap latch standard

 Draw-cord

 Left

 Right

 Crank rod

 Left

 Right

 1500mm

 2000mm

 other lengths(mm) _____

 Electric motor with chain-drive

 24V DC

 230V AC

Locking bolt height

 Centre position

 Standard: 1100mm

 Other:min.300(mm) _____ from u/s floor guide

Alu-frame

 Inside

 Natur. anod.

 RAL 9010

 Other Colour _____

 Outside

 Natur. anod.

 RAL 9010

 Other Colour _____

Glazing

 With

 Without

 double glazed 24mm

 prepared for (mm) _____

Ironmongery

 Inside

 Black

 White

 Aluminium col.

 Outside

 Black

 White

 Aluminium col.

EPDM/TPV

 Inside

 Black

 White

 Grey

Gaskets

 Outside

 Black

 White

 Grey

 silicone-free

Compensation profile* 54mm

 Top

 Bottom

 Left**

 Right**

Remark _____

***Watch the height! **Inside view**

FORM_V_TH_60



Kunde _____

Komm. _____

Termin KW [min. 4 Wochen] _____

E-Mail: _____

Ort/Datum _____

Anzahl Beilagen (Plan/Skizze): _____

Unterschrift _____

Verglasung von innen gesehen

 Festverglasung

 Kippflügel

 Drehflügel links

 Doppelfenster

 Erstöffnend: Links Rechts

 Drehflügel rechts

 Doppelfenster
mit Dreh-Kippflügel links

 Dreh-Kippflügel links

 Doppelfenster
mit Dreh-Kippflügel rechts

 Dreh-Kippflügel rechts

 mit Kantriegel

Plan/Skizze von innen gesehen

Dimension

Breite(mm) _____

Höhe(mm) _____ Sprossenhöhe – o.k. Sprosse(mm) _____

**Oberlicht-
öffner**
 Schnäpper Standard

 Schnurzug

 Links

 Rechts

 Kurbelstange

 Links

 Rechts

 1500mm

 2000mm

 andere Länge(mm) _____

 Motor mit Kettenantrieb

 24V DC

 230V AC

**Verschluss-
riegelhöhe**
 mittig

 Standard: 1100mm

 Andere: min. 300(mm) _____ ab u.k. Bodenführung

Aluprofile

Innen

 natur elox.

 RAL 9010

 andere Farbe _____

Aussen

 natur elox.

 RAL 9010

 andere Farbe _____

Verglasung
 Mit

 Ohne

 Isolierglas – Dicke 24mm

 hergerichtet für(mm) _____

Beschläge

Innen

 Schwarz

 Weiss

 Alu-farbig

Aussen

 Schwarz

 Weiss

 Alu-farbig

EPDM/TPV

Innen

 Schwarz

 Weiss

 Grau

Dichtung

Aussen

 Schwarz

 Weiss

 Grau

 silikonfrei

Ausgleichsprofil* 54mm
 Oben

 Unten

 Links**

 Rechts**

Bemerkung _____

*Höhe beachten **Von innen

FORM_V_TH_60

